

GCSE Transition questions

These questions are AS standard questions that are effectively extension questions of (what should be) your existing GCSE knowledge. Have a go at answering them – if you get stuck, go back to your GCSE notes/revision guide and look again at that topic.

Q1. (a) An ion of plutonium ${}^{239}_{94}\text{Pu}$ has an overall charge of $+1.6 \times 10^{-19}\text{C}$.

For this ion state the number of

- (i) protons _____
- (ii) neutrons _____
- (iii) electrons _____

(3)

(b) Plutonium has several *isotopes*.

Explain the meaning of the word isotopes.

(2)

(Total 5 marks)

Q2. (a) (i) State the difference between a longitudinal wave and a transverse wave.

(2)

(ii) State an example of a transverse wave.

(1)

(iii) State an example of a longitudinal wave.

(1)

(b) Sound with a frequency of 560 Hz travels through steel with a speed of 4800 m s^{-1} . Calculate the wavelength of the sound wave.

(2)

(Total 6 marks)

Q3. (a) For a sound wave travelling through air, explain what is meant by these terms

Particle displacement

amplitude

wavelength

(4)

(b)

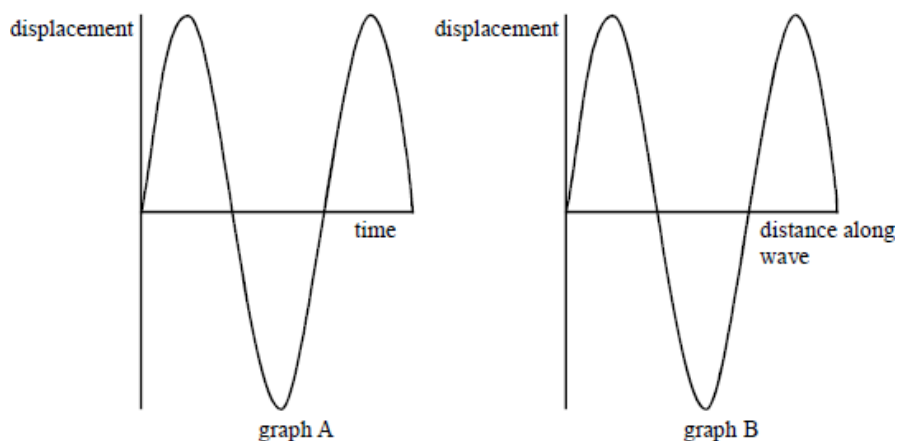

Graph A shows the variation of particle displacement with **time** at a point on the path of a progressive wave of constant amplitude.

Graph B shows the variation of particle displacement with **distance** along the same wave at a particular instant.

(i) Show on graph A

(1) the wave amplitude, a ,

(2) the period, T , of the vibrations providing the wave.

(ii) Show on graph B

(1) the wavelength of the wave, λ ,

(3)

(Total 7 marks)

Q4. The Soyuz Spacecraft is used to transport astronauts to and from an orbiting space station. The spacecraft is made up of three sections as shown in **Figure 1**.

Figure 1

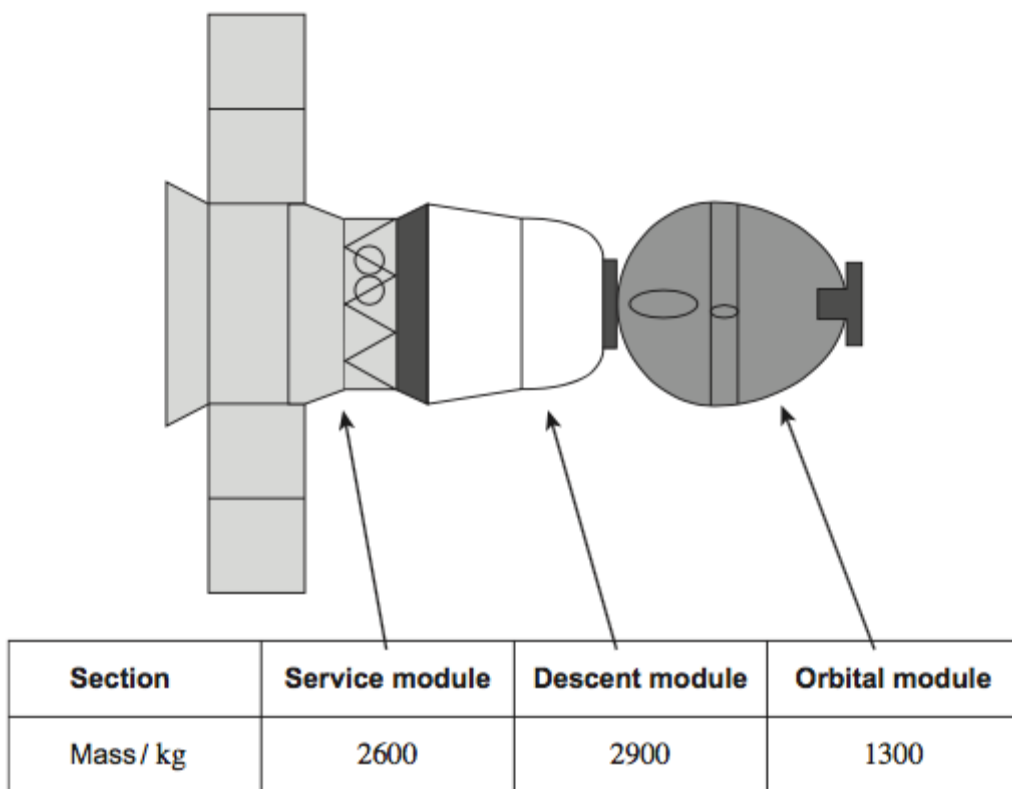

- (a) On leaving the space station the spacecraft is given an initial horizontal thrust of 1400 N. Calculate the initial acceleration of the spacecraft during the firing of the thruster engines.

acceleration = _____ m s⁻²

(2)

- (b) Newton's Third Law refers to pairs of forces.

- (i) State **one** way in which a pair of forces referred to in Newton's Third Law are the same.

(1)

- (ii) State **one** way in which a pair of forces are different.

(1)

- (c) When the spacecraft returns to the Earth's atmosphere the orbital module and the service module are separated from the descent module. This descent module has its speed greatly reduced by drag from the atmosphere.

Figure 2 shows two of the forces acting on the descent module as it travels down through the atmosphere.

Figure 2



State **one** reason why the two forces shown in **Figure 2** are **not** a pair of forces as referred to in Newton's Third Law.

(1)

- (d) In one particular descent, the descent module has its speed reduced to 5.5 m s^{-1} by parachutes. The descent module also releases its empty tanks and shield to reduce its mass to 890 kg .

A final speed reduction can be carried out by using engines which operate for a maximum time of 3.5 s . When the engines are in use, the resultant upward force on the descent module is 670 N . The safe landing speed of the descent module is 3.0 m s^{-1} .

Determine whether these engines are able to reduce the speed of the descent module to its safe value.

At these landing speeds atmospheric drag is negligible.

(3)

(Total 8 marks)

Q5. The figure below shows two resistors, R_1 and R_2 , connected in series with a battery of emf 12 V and negligible internal resistance.

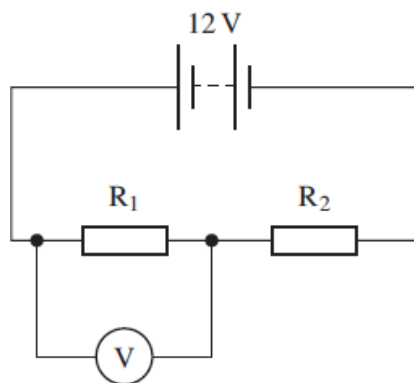

(a) The reading on the voltmeter is 8.0 V and the resistance of R_2 is 60 Ω .

(i) Calculate the current in the circuit.

answer = _____ A (2)

(ii) Calculate the resistance of R_1 .

answer = _____ Ω (1)

(iii) Calculate the charge passing through the battery in 2.0 minutes. Give an appropriate unit for your answer.

answer = _____ unit = _____ (2)

(b) In the circuit shown in the figure above R_2 is replaced with a thermistor. State and explain what will happen to the reading on the voltmeter as the temperature of the thermistor increases.

(3)
(Total 8 marks)